

## KS Series – 3/8” (9.53 mm) Solenoids

- ▶ 2-Way, Normally Closed
- ▶ MOPD: 20 PSIG (1.38 bar)
- ▶ C<sub>v</sub> Range: 0.008 to 0.015
- ▶ 1.8 Watts

KS Series isolation valves are 2-way, Normally Closed (NC) valves featuring 0.38” (10 mm) solenoid shell diameters. The isolation valve design ensures that the only wetted parts are the valve diaphragm and the valve body. For exceptional chemical compatibility the KS Series utilizes PEEK or PPS bodies, with a choice of diaphragm materials to meet your specific needs.

### How To Order

Use the **Bold** characters from the choices listed on the following page to construct a product code.

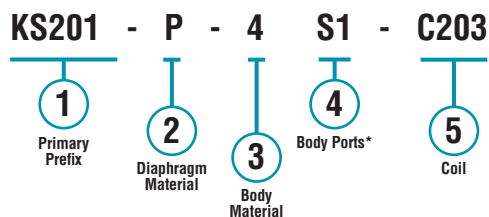

\* Combination of Body Port Configuration and Port Thread; Manifold Mount (BM) does **not** use the Thread Size designator

#### Example:

KS201-P-4 S1-C203

Small 2-Way N.C. Perfluoroelastomer solenoid valve, with a Polyaryletheretherketone body and 1/4”-28 UNF flat bottom threaded side ports, operating at 12 VDC.

### Part Prefix Table ①

	Orifice (inch)	MOPD*		C <sub>v</sub>	Internal Volume (μl)			① Primary Prefix
		psig	bar		Side Ports	Bottom Ports	Manifold Mount	
<b>2-WAY</b>	0.032	20	1.38	0.008	20	18	13	<b>KS201</b>
<b>N.C.</b>	0.054	20	1.38	0.015	42	35	21	<b>KS203</b>

\* Maximum Operational Pressure Differential

#### ② Diaphragm Material

- T = PTFE Polytetrafluoroethylene
- E = EPDM Ethylene Propylene Diene (M)
- P = FFKM Perfluoroelastomer

#### ③ Body Material

- 3 = PPS Polyphenylene Sulfide
- 4 = PEEK Polyaryletheretherketone

#### ④ Body Port Configuration

- BM = Manifold mount
- S\_ = Threaded side port
- B\_ = Threaded bottom port

Port Thread (Used in conjunction with Threaded Port Configurations)

- 1 = 1/4”-28 UNF flat bottom (Standard)
- 2 = 10-32
- 3 = 5/16”-24
- 4 = 1/8” NPT
- 5 = M6 X 1,0

#### ⑤ Coil

- C203 = 12 VDC
- C204 = 24 VDC

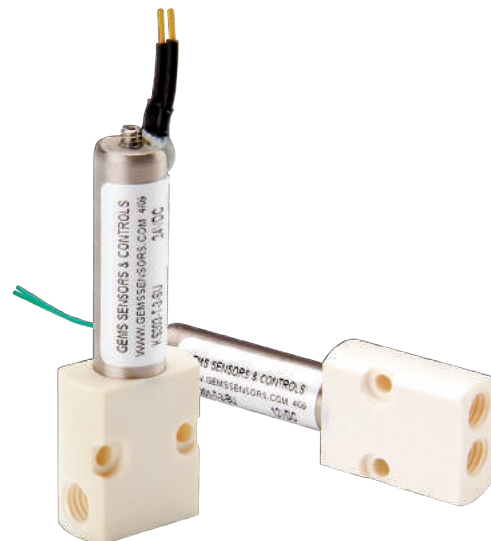

Dimensions – Threaded Port Body

Side Port

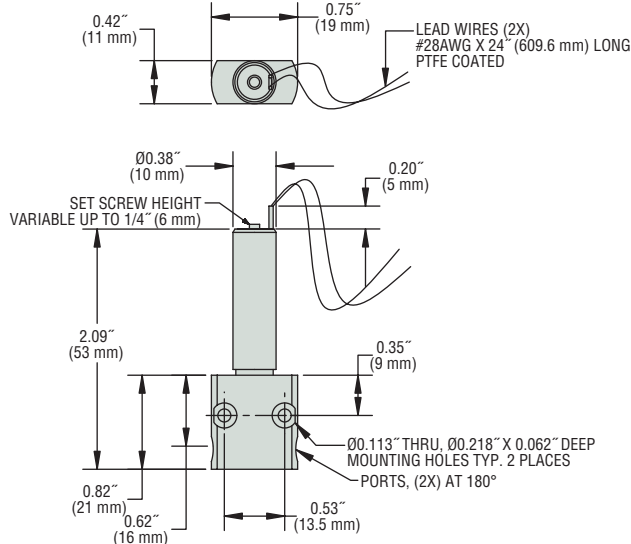

Bottom Port

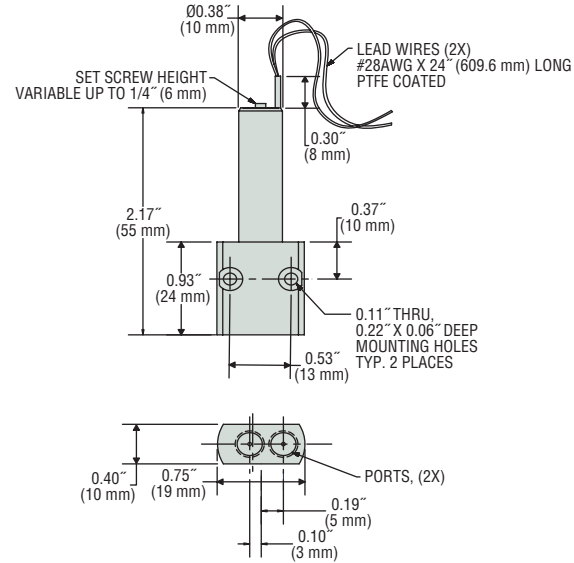

Dimensions – Manifold Mount Body

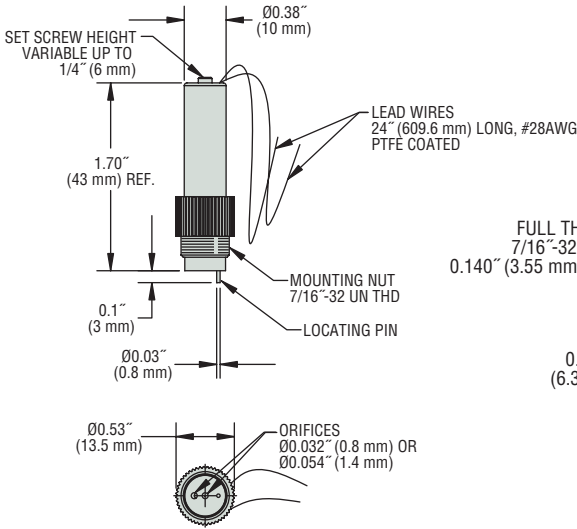

Manifold Preparation

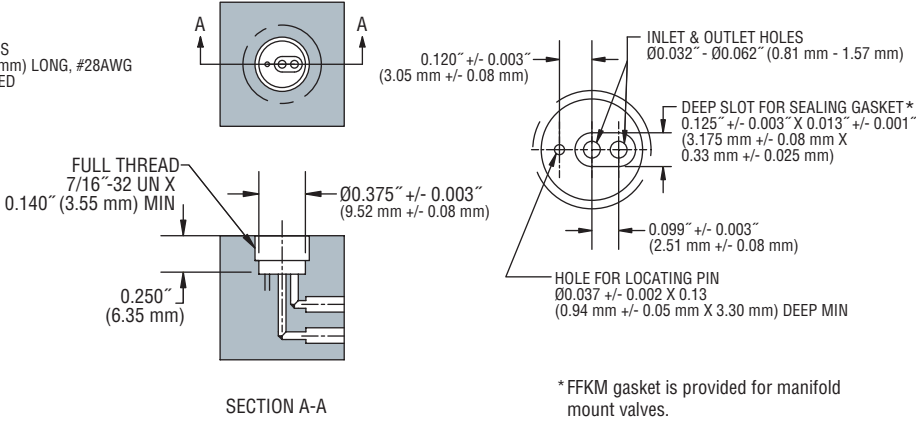

\* FFKM gasket is provided for manifold mount valves.

Gems specializes in the design and manufacturing of custom solenoid valves and fluidic systems. If you don't see what you're looking for, or have a question, contact us at 800-378-1600 or info@gemssensors.com.